

Specifications

Main unit

Power supply		AC 100V - 240V, (4.2A-1.8A) 50Hz/60Hz
Power consumption		410W NORMAL: 410W ECO: 335W SHUTTER: 63W STANDBY MODE [ECO]*1: 0.4W STANDBY MODE [NORMAL]: 18W [STANDBY MODE] is set to [NORMAL]: [AUDIO SETTING] → [IN STANDBY MODE] is set to [ON]: 45W
BTU value		Max 1400BTU
LCD panel	Panel size	16.3 mm (0.64 in) diagonal (16:10 aspect ratio)
	Projection system	Transparent LCD panel (× 3, R/G/B)system
	Pixels	1,024,000 (1280 × 800)
Light source		Laser Diode
Light output		6000 lm (When [LIGHT POWER] is set to [NORMAL]) ^{*2} ([INPUT SIGNAL] is set to [PC], [PICTURE MODE] is set to [DYNAMIC], [DAYLIGHT VIEW] is set to [OFF], [AUTO POWER SAVE] is set to [OFF]) 4000 lm (When [LIGHT POWER] is set to [ECO][QUIET]) ^{*3}
Time until light output declines to 50 % ^{*4}		20,000 hours
Filter Replacement Cycle ^{*5}		20,000 hours (Under the dust conditions of 0.08mg/m ³) 10,000 hours (Under the dust conditions of 0.15mg/m ³) Filter can be washed and reused up to two times.
Resolution		1280 × 800 pixels (Input signals that exceed this resolution will be converted to 1290 x 800 pixels.)
Contrast ratio ^{*2}		3,000,000:1 (All White/All Black) (When [PICTURE MODE] is set to [DYNAMIC], [DYNAMIC CONTRAST] is set to [1])
Screen size		0.76–7.62 m (30–300 inches) (16:10 aspect ratio)
Center to corner zone ratio ^{*2}		85%
Lens		1.6x Manual zoom (Throw ratio:1.09-1.77:1) / Manual focus lens, F=1.6–2.12, f=15.30–24.64 mm
Compatible signal	VIDEO	fH: 15.73 kHz / 15.63 kHz fV: 59.94 Hz / 50 Hz
	RGB	Resolution: 640 × 400 to 1920 × 1200 Dot clock frequency: 162 MHz or less PIAS (Panasonic Intelligent Auto Scanning) system
	YPbPr (YCbCr)	Resolution: 480i/576i to 1920 × 1080 Dot clock frequency: 148.5 MHz or less The HD/SYNC and VD terminals do not support 3 value SYNC.
	HDMI	Moving image signal resolution: 480i ^{*6} /576i ^{*6} to 4096 × 2160 Still image signal resolution: 640 × 400 to 1920 × 1200 (non-interlace) Dot clock frequency: 25 MHz to 297 MHz
	DIGITAL LINK	Moving image signal resolution: 480i ^{*6} /576i ^{*6} to 4096 × 2160 Still image signal resolution: 640 × 400 to 1920 × 1200 (non-interlace) Dot clock frequency: 25 MHz to 297 MHz

Keystone correction range

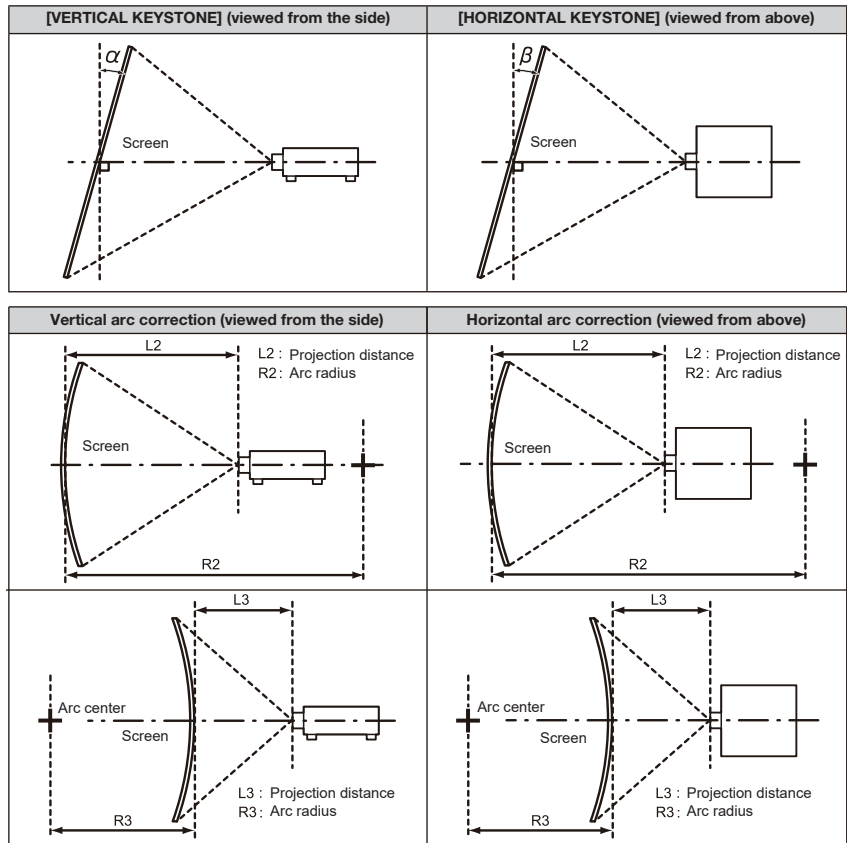

Model No.	Only [KEYSTONE] used		[KEYSTONE] and [CURVED] used together		Only [CURVED] used			
	Vertical keystone correction angle α (°)	Horizontal keystone correction angle β (°)	Vertical keystone correction angle α (°)	Horizontal keystone correction angle β (°)	Min. value of R2/L2	Min. value of R3/L3	Min. value of R2/L2	Min. value of R3/L3
PT-VMW60	± 35	± 35	± 35	± 35	1.4	2.9	0.7	1.6

- When [SCREEN ADJUSTMENT] is used, the focus may not be able to match the whole screen as correction increases.
- The curved screen should be in the shape of a circular arc part of a perfect circle.

Optical axis shift	Vertical: +44%, 0% (manual) Horizontal: +20%, -20% (manual)
Installation	Ceiling/floor, front/rear
Speaker	4.0 cm round-type × 1
Maximum usable volume output	10W (monaural)
Terminals	<p>COMPUTER 1 IN high-density D-Sub 15 p (female) × 1 [RGB signal] R: 0.7 Vp-p, 75 ohms, G: 0.7 Vp-p (G: 1.0 Vp-p for sync on G), 75 ohms, B: 0.7 Vp-p, 75 ohms HD, VD/SYNC: TTL, high impedance, positive/negative automatic [YPbPr signal] Y: 1.0 Vp-p (including sync signal), Pb/Pr (Cb/Cr): 0.7 Vp-p, 75 ohms</p> <p>COMPUTER 2 IN / 1 OUT high-density D-Sub 15 p (female) × 1 [RGB signal] R: 0.7 Vp-p, 75 ohms, G: 0.7 Vp-p (G: 1.0 Vp-p for sync on G), 75 ohms, B: 0.7 Vp-p, 75 ohms HD, VD/SYNC: TTL, high impedance, positive/negative automatic [YPbPr signal] Y: 1.0 Vp-p (including sync signal), Pb/Pr (Cb/Cr): 0.7 Vp-p, 75 ohms</p> <p>VIDEO IN Pin jack × 1 1.0 Vp-p, 75 ohms</p> <p>HDMI 1 IN HDMI 19 pin × 2, HDCP and Deep color compatible</p> <p>HDMI 2 IN Audio signals : Linear PCM (Sample frequency : 48 kHz/44.1 kHz/32 kHz) 4K/30p signal input compatible</p> <p>AUDIO IN 1 AUDIO IN 2 M3 stereo mini jack × 2, 0.5 V[rms], input Impedance 22 k ohms and more</p> <p>AUDIO IN 3 Pin jack × 2(L-R), 0.5 V[rms], input Impedance 22 k ohms and more</p> <p>VARIABLE AUDIO OUT M3 stereo mini jack × 1, 0 V[rms] to 2.0 V[rms] variable, output Impedance 2.2 k ohms and less</p> <p>USB [VIEWER/WIRELESS/DC OUT] USB connector(type A) × 1 for Memory Viewer/Wireless Module (Out put 5V MAX 2A On standby, power supply is impossible when [STANDBY MODE] is set to [ECO].)</p> <p>SERIAL IN D-sub 9 pin × 1, RS-232C compliant, for computer control use</p>

Terminals	DIGITAL LINK/LAN	RJ-45 × 1 for network and DIGITAL LINK (video/network/serial control) (HDBaseT™ compliant), PJLink™ (class 2) compatible, 100Base-TX, HDCP compatible, Deep Color compatible 4K/30p signal input compatible
	LAN	RJ-45 × 1 for network connection, PJLink™ (class 2) compatible, 10Base-T/100Base-TX
Power cord length		2.0 m (6 ft 7 in)
Cabinet materials		Molded plastic
Dimensions (W × H × D)		399 x 133*7 x 348mm (15-23/32 x 5-1/4*7 x 13-11/16in)
Weight		Approx. 7.2 kg (15.9 lbs.)
Operation noise		37 dB[When [LIGHT POWER] is set to [NORMAL]] / 27 dB[When [LIGHT POWER] is set to [QUIET]]
Laser Classification	Laser Class	USA and Canada: Class 3R (IEC 60825-1:2007) Other countries or regions: Class 1 (IEC/EN 60825-1:2014)
	Risk Group	Risk Group 2 (IEC 62471-5:2015)
Operating temperature		0–45 °C (32–113 °F)*8
Operating humidity		20%–80% (no condensation)

NOTE:

The <DIGITAL LINK/LAN> terminal and the <LAN> terminal are connected inside the projector. When using both the <DIGITAL LINK/ LAN> terminal and the <LAN> terminal, configure the system to prevent them from being connected to the same network directly or via the peripheral devices such as a hub or twisted-pair-cable transmitter.

Remote control unit

Power supply	3 V DC (AAA/R03/LR03 battery × 2)
Operation range	Approx. 30 m (98 ft 5 in) when operated from directly in front of the signal receptor
Dimensions (W × H × D)	48 × 145 × 27 mm (1-7/8 × 5-23/32 × 1-1/16 in)
Weight*9	Approx. 102 g (3.6 ozs.) including batteries

Other Applications

Multi Monitoring and Control Software (for Windows)
Logo Transfer Software (for Windows)
Presenter Light Software (for Windows)
Wireless Projector (for iOS / Android)

Supplied accessories

Power cord with secure lock (× 1) (× 2 for Europe / ASIA models)
Wireless remote control unit (× 1)
Batteries for remote control (AAA/R03 or AAA/LR03 battery × 2)
Lens cap (× 1)
String (× 1) (for lens cap)

Optional accessories

Digital interface box ET-YFB100G
Digital LINK Switcher ET-YFB200G
Ceiling mount bracket ET-PKL100H (for high ceilings)
ET-PKL100S (for low ceilings)
Attachment for ceiling mount bracket ET-PKV400B
Early Warning Software ET-SWA100*10
Replacement Filter Unit ET-RFV500
Wireless module AJ-WM50*11

- *1 When the standby mode is set to ECO, network functions such as power on over the LAN network will not operate, Only certain commands can be received for external control using the serial terminal.
- *2 Measurement, measuring conditions, and method of notation all comply with ISO/IEC 21118:2012 international standards.
- *3 Indicated average light-output value of all shipper products.
- *4 Around this time, light output will have decreased by approximately 50 %. IEC62087: 2008 Broadcast contents, NORMAL Mode, Dynamic Contrast [2], under conditions with 30 °C (86 °F), 700 m (2,297 ft) above sea level, and 0.15 mg/m3 of particulate matter. Estimated time until light output declines to 50 % varies depending on environment.
- *5 Usage environment affects the duration of filter.
- *6 Pixel-Repetition signal (dot clock frequency 27.0 MHz) only
- *7 With legs at shortest position.
- *8 The projector cannot be used at an altitude of 2 700 m (8 858') or higher above sea level.
In the following operating environment, the light output may decrease to protect the projector.
 - When the projector is operated at an altitude below 700 m (2 297') and the ambient temperature exceeds 36°C (97°F)
 - When the projector is operated at an altitude between 700 m (2 297') and 1 400 m (4 593') exclusive and the ambient temperature exceeds 34°C (93°F)
 - When the projector is operated at an altitude between 1 400 m (4 593') and 2 100 m (6 890') exclusive and the ambient temperature exceeds 32°C (90°F)
 - When the projector is operated at an altitude between 2 100 m (6 890') and 2 700 m (8 858') exclusive and the ambient temperature exceeds 30°C (86°F)
- *9 Average value. Weight varies for each product.
- *10 Part number suffix may differ depending on the license type.
- *11 In this document, the suffixes at the end of the model numbers are omitted.

NOTE:

The optional wireless module (Model No: AJ-WM50) should be used within the environmental temperature range of 0°C (32°F) to 40°C (104°F) when attached to the projector.

Dimensions

unit : mm (inch)

NOTE: This illustration is not drawn to scale.

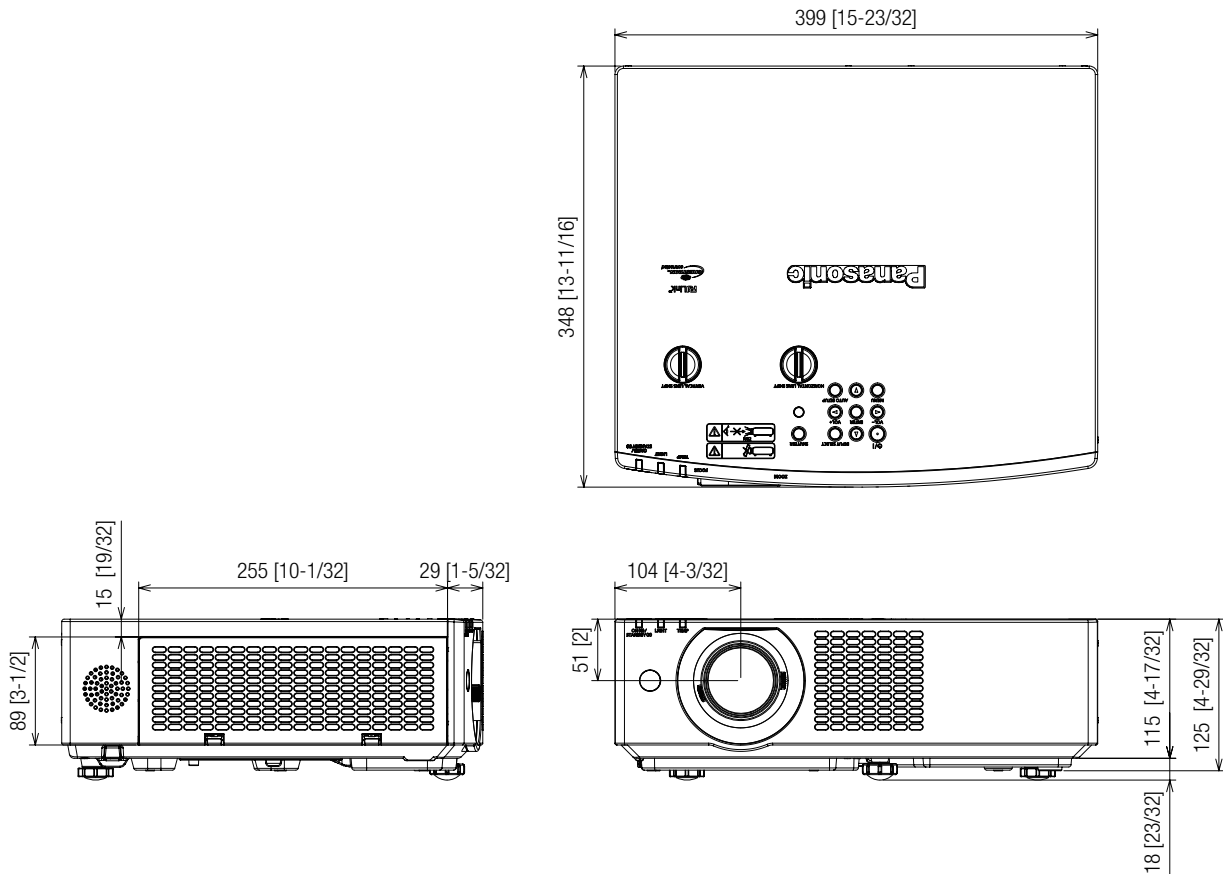

Terminals

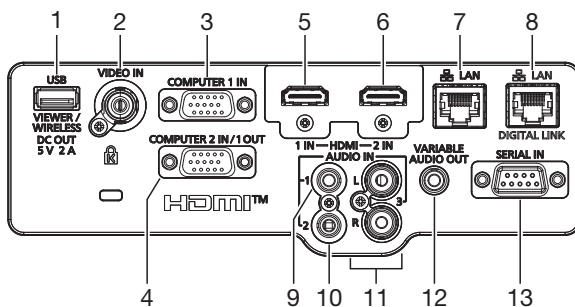

- 1 USB [VIEWER/WIRELESS/DC OUT] TERMINAL
- 2 VIDEO INPUT TERMINAL
- 3 COMPUTER 1 INPUT TERMINAL
- 4 COMPUTER 2 INPUT TERMINAL / 1 OUTPUT TERMINAL
- 5 HDMI 1 INPUT TERMINAL
- 6 HDMI 2 INPUT TERMINAL
- 7 LAN TERMINAL
- 8 DIGITAL LINK/LAN TERMINAL
- 9 AUDIO IN 1 TERMINAL
- 10 AUDIO IN 2 TERMINAL
- 11 AUDIO IN 3 TERMINAL
- 12 VARIABLE AUDIO OUT TERMINAL
- 13 SERIAL INPUT TERMINAL

Standard setting-up position

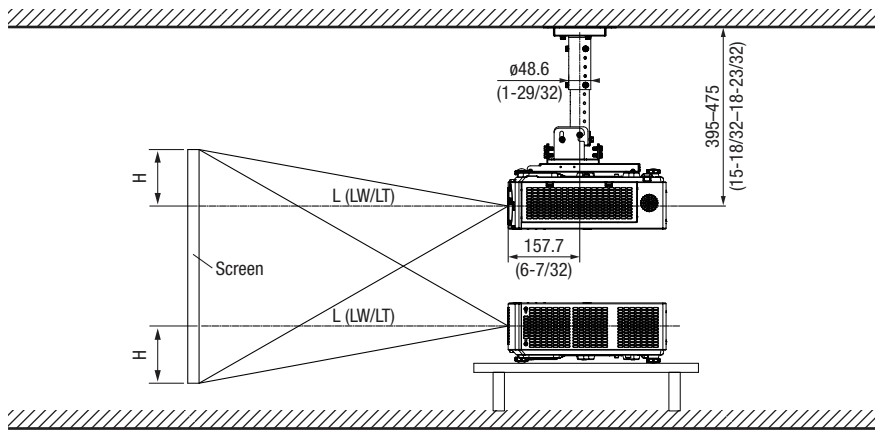

unit : mm (inch)

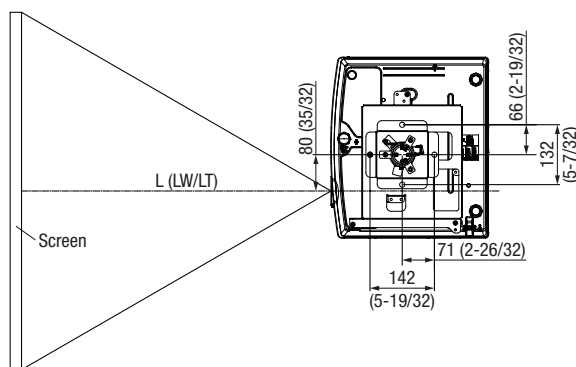

NOTE:

Illustrations show the projector installed using optional ceiling mount bracket ET-PKL100H and projector mount bracket ET-PKV400B. This illustration is not drawn to scale.

Caution:

- All construction work should be done by a qualified technician.
- When mounting to the ceiling, use the special mounting bracket. Furthermore, in order to prevent it from falling down from the ceiling, use the supplied wire on the mounting bracket.

Projection distance for 16:10 aspect ratio screen

unit: meters (feet)

Projection size [diagonal]	Projection distance [L]		Height from the edge of screen to center of lens [H]	
	Min [wide]	Max [telephoto]		
0.76 m / 30"	0.68 (2.23)	1.12 (3.67)	0.022 – 0.201	(0.072 – 0.659)
1.02 m / 40"	0.93 (3.05)	1.51 (4.95)	0.030 – 0.270	(0.098 – 0.886)
1.27 m / 50"	1.16 (3.81)	1.89 (6.20)	0.037 – 0.337	(0.121 – 1.106)
1.52 m / 60"	1.39 (4.56)	2.26 (7.41)	0.045 – 0.403	(0.148 – 1.322)
1.78 m / 70"	1.64 (5.38)	2.66 (8.73)	0.052 – 0.472	(0.171 – 1.549)
2.03 m / 80"	1.87 (6.14)	3.03 (9.94)	0.060 – 0.538	(0.197 – 1.765)
2.29 m / 90"	2.12 (6.96)	3.43 (11.25)	0.067 – 0.607	(0.220 – 1.991)
2.54 m / 100"	2.35 (7.71)	3.80 (12.47)	0.075 – 0.673	(0.246 – 2.208)
3.05 m / 120"	2.83 (9.28)	4.57 (14.99)	0.090 – 0.808	(0.295 – 2.651)
3.81 m / 150"	3.54 (11.61)	5.72 (18.77)	0.112 – 1.010	(0.367 – 3.314)
5.08 m / 200"	4.73 (15.52)	7.64 (25.07)	0.150 – 1.346	(0.492 – 4.416)
6.35 m / 250"	5.92 (19.42)	9.56 (31.36)	0.187 – 1.683	(0.614 – 5.522)
7.62 m / 300"	7.11 (23.33)	11.48 (37.66)	0.224 – 2.019	(0.735 – 6.624)

Projection distance for 16:9 aspect ratio screen

unit: meters (feet)

Projection size [diagonal]	Projection distance [L]		Height from the edge of screen to center of lens [H]	
	Min [wide]	Max [telephoto]		
0.76 m / 30"	0.70 (2.30)	1.15 (3.77)	0.002 – 0.186	(0.007 – 0.610)
1.02 m / 40"	0.95 (3.12)	1.55 (5.09)	0.003 – 0.250	(0.010 – 0.820)
1.27 m / 50"	1.19 (3.90)	1.94 (6.36)	0.004 – 0.311	(0.013 – 1.020)
1.52 m / 60"	1.43 (4.69)	2.33 (7.64)	0.005 – 0.372	(0.016 – 1.220)
1.78 m / 70"	1.69 (5.54)	2.73 (8.96)	0.005 – 0.436	(0.016 – 1.430)
2.03 m / 80"	1.93 (6.33)	3.12 (10.24)	0.006 – 0.497	(0.020 – 1.631)
2.29 m / 90"	2.18 (7.15)	3.52 (11.55)	0.007 – 0.561	(0.023 – 1.841)
2.54 m / 100"	2.42 (7.94)	3.91 (12.83)	0.008 – 0.622	(0.026 – 2.041)
3.05 m / 120"	2.91 (9.55)	4.70 (15.42)	0.009 – 0.747	(0.030 – 2.451)
3.81 m / 150"	3.64 (11.94)	5.88 (19.29)	0.012 – 0.933	(0.039 – 3.061)
5.08 m / 200"	4.86 (15.94)	7.85 (25.75)	0.015 – 1.245	(0.049 – 4.085)
6.35 m / 250"	6.09 (19.98)	9.83 (32.25)	0.019 – 1.556	(0.062 – 5.105)
7.62 m / 300"	7.31 (23.98)	11.80 (38.71)	0.023 – 1.867	(0.075 – 6.125)

Calculation of the projection distance

For a screen size different from the above, use the equation below to calculate the projection distance.

Aspect ratio 16:10

minimum L (m) = (diagonal screen size in inches) × 0.0238 – 0.0294

maximum L (m) = (diagonal screen size in inches) × 0.0384 – 0.0319

Aspect ratio 16:9

minimum L (m) = (diagonal screen size in inches) × 0.0245 – 0.0294

maximum L (m) = (diagonal screen size in inches) × 0.0394 – 0.0319

Aspect ratio 4:3

minimum L (m) = (diagonal screen size in inches) × 0.0269 – 0.0294

maximum L (m) = (diagonal screen size in inches) × 0.0434 – 0.0319

NOTE:

Distances calculated with the above equations will include a slight error.

- The value for L (distance to screen) varies slightly within ±5% depending on the zoom lens characteristics.
- When keystone correction is used, the image is corrected in the direction that reduces its projected size.

Shift range

Optical axis shift function allows to shift the position of a projected image as shown below.

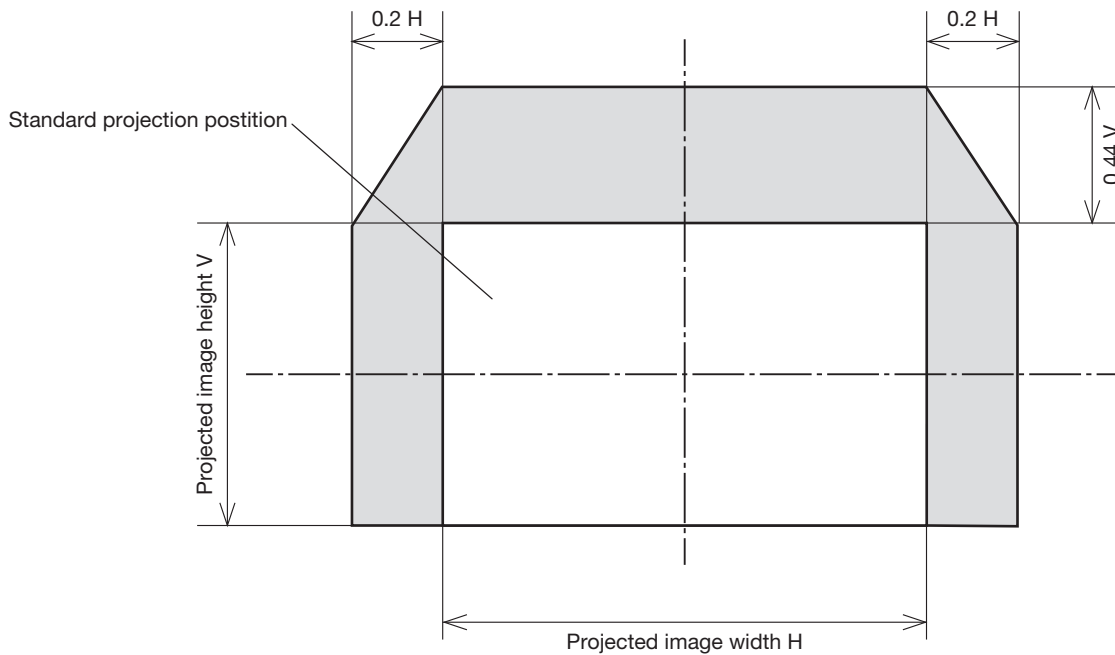

Installable angle

Install the projector at an angle within the range shown below.

FULL 360-degree projection

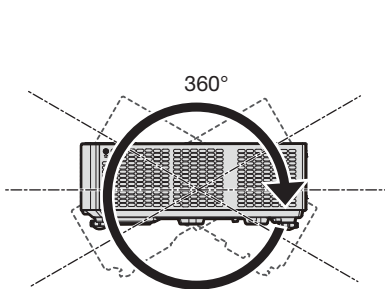

360° vertically

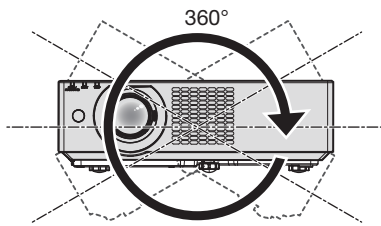

360° horizontally

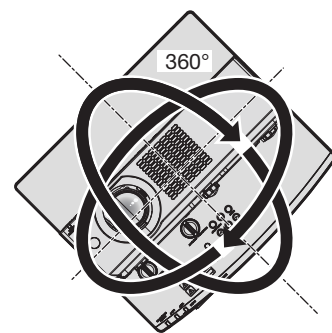

**360° tilted
(combination of vertical and horizontal)**

List of compatible signals

The following table specifies the video signals compatible with the projector. This projector supports the signal with ✓ in the compatible signal column.

- Symbols that indicate formats are as follows.
 - V : VIDEO
 - R : RGB
 - Y : YC_BC_R/YP_BP_R
 - H : HDMI/DIGITAL LINK
- Input corresponding to each item in the plug and play column is as follows.
 - COMPUTER: COMPUTER1 / COMPUTER2 input
 - HDMI: HDMI1 / HDMI2 input
 - DIGITAL LINK: DIGITAL LINK input

Signal name	Resolution(Dots)	Scanning freq.		Dot clock freq. (MHz)	Format	Plug and play correspondence*1	
		Horizontal (kHz)	Vertical (Hz)			COMPUTER	HDMI/DIGITAL LINK
NTSC/NTSC4.43/ PAL-M/PAL60	720 x 480i	15.7	59.9	—	V	—	—
PAL/PAL-N/SECAM	720 x 576i	15.6	50.0	—	V	—	—
480 /60i	720 x 480i	15.7	59.9	13.5	R/Y	—	—
576 /50i	720 x 576i	15.6	50.0	13.5	R/Y	—	—
480 /60i	720(1 440) x 480i*2	15.7	59.9	27.0	H	—	—
576 /50i	720(1 440) x 576i*2	15.6	50.0	27.0	H	—	—
480 /60p	720 x 480	31.5	59.9	27.0	R/Y/H	—	✓
576 /50p	720 x 576	31.3	50.0	27.0	R/Y/H	—	✓
720 /60p	1 280 x 720	45.0	60.0*3	74.3	R/Y/H	—	✓
720 /50p	1 280 x 720	37.5	50.0	74.3	R/Y/H	—	✓
1080 /60i	1 920 x 1 080i	33.8	60.0*3	74.3	R/Y/H	—	✓
1080 /50i	1 920 x 1 080i	28.1	50.0	74.3	R/Y/H	—	✓
1080 /24p	1 920 x 1 080	27.0	24.0*3	74.3	R/Y/H	—	✓
1080 /24sF	1 920 x 1 080i	27.0	48.0*3	74.3	R/Y/H	—	—
1080 /25p	1 920 x 1 080	28.1	25.0	74.3	R/Y/H	—	—
1080 /30p	1 920 x 1 080	33.8	30.0*3	74.3	R/Y/H	—	—
1080 /60p	1 920 x 1 080	67.5	60.0*3	148.5	R/Y/H	—	✓
1080 /50p	1 920 x 1 080	56.3	50.0	148.5	R/Y/H	—	✓
3840 x 2160/24p	3840 x 2160	54.0	24.0*3	297.0	H	—	✓
3840 x 2160/25p	3840 x 2160	56.3	25.0	297.0	H	—	✓
3840 x 2160/30p	3840 x 2160	67.5	30.0*3	297.0	H	—	✓
4096 x 2160/24p	4096 x 2160	54.0	24.0*3	297.0	H	—	✓
4096 x 2160/25p	4096 x 2160	56.3	25.0	297.0	H	—	✓
4096 x 2160/30p	4096 x 2160	67.5	30.0*3	297.0	H	—	✓
640 x 400/70	640 x 400	31.5	70.1	25.2	R/H	—	—
640 x 400/85	640 x 400	37.9	85.1	31.5	R/H	—	—
640 x 480/60	640 x 480	31.5	59.9	25.2	R/H	✓	✓
640 x 480/67	640 x 480	35.0	66.7	30.2	R/H	—	—
640 x 480/73	640 x 480	37.9	72.8	31.5	R/H	✓	✓
640 x 480/75	640 x 480	37.5	75.0	31.5	R/H	✓	✓
640 x 480/85	640 x 480	43.3	85.0	36.0	R/H	—	—
800 x 600/56	800 x 600	35.2	56.3	36.0	R/H	✓	✓
800 x 600/60	800 x 600	37.9	60.3	40.0	R/H	✓	✓
800 x 600/72	800 x 600	48.1	72.2	50.0	R/H	✓	✓
800 x 600/75	800 x 600	46.9	75.0	49.5	R/H	✓	✓
800 x 600/85	800 x 600	53.7	85.1	56.3	R/H	—	—
832 x 624/75	832 x 624	49.7	74.6	57.3	R/H	✓	✓
1024 x 768/50*4	1 024 x 768	39.6	50.0	51.9	R/H	—	—
1024 x 768/60	1 024 x 768	48.4	60.0	65.0	R/H	✓	✓
1024 x 768/70	1 024 x 768	56.5	70.1	75.0	R/H	✓	✓
1024 x 768/75	1 024 x 768	60.0	75.0	78.8	R/H	✓	✓
1024 x 768/82	1 024 x 768	65.5	81.6	86.0	R/H	—	—
1024 x 768/85	1 024 x 768	68.7	85.0	94.5	R/H	—	—

Signal name	Resolution(Dots)	Scanning freq.		Dot clock freq. (MHz)	Format	Plug and play correspondence*1	
		Horizontal (kHz)	Vertical (Hz)			COMPUTER	HDMI/DIGITAL LINK
1024 x 768/100	1 024 x 768	81.4	100.0	113.3	R/H	—	—
1152 x 864/60	1 152 x 864	53.7	60.0	81.6	R/H	—	—
1152 x 864/75	1 152 x 864	67.5	75.0	108.0	R/H	—	—
1152 x 864/85	1 152 x 864	77.1	85.0	119.7	R/H	—	—
1152 x 870/75	1 152 x 870	68.7	75.1	100.0	R/H	✓	✓
1280 x 720/50	1 280 x 720	37.1	49.8	60.5	R/H	—	—
1280 x 720/60	1 280 x 720	44.8	59.9	74.5	R/H	—	—
1280 x 768/60*4	1 280 x 768	47.7	60.0	80.1	R/H	—	—
1280 x 768/60	1 280 x 768	47.8	59.9	79.5	R/H	—	—
1280 x 768/75	1 280 x 768	60.3	74.9	102.3	R/H	—	—
1280 x 768/85	1 280 x 768	68.6	84.8	117.5	R/H	—	—
1280 x 800/50	1 280 x 800	41.3	50.0	68.0	R/H	—	—
1280 x 800/60	1 280 x 800	49.7	59.8	83.5	R/H	✓	✓
1280 x 800/75	1 280 x 800	62.8	74.9	106.5	R/H	—	—
1280 x 800/85	1 280 x 800	71.6	84.9	122.5	R/H	—	—
1280 x 960/60	1 280 x 960	60.0	60.0	108.0	R/H	—	—
1280 x 1024/60*4	1 280 x 1 024	64.0	60.0	108.0	R/H	—	—
1280 x 1024/75	1 280 x 1 024	80.0	75.0	135.0	R/H	✓	✓
1280 x 1024/85	1 280 x 1 024	91.1	85.0	157.5	R/H	—	—
1366 x 768/50	1 366 x 768	39.6	49.9	69.0	R/H	—	—
1366 x 768/60	1 366 x 768	47.7	59.8	85.5	R/H	—	—
1366 x 768/60*4	1 366 x 768	47.7	60.0	84.7	R/H	—	—
1400 x 1050/60	1 400 x 1 050	65.3	60.0	121.8	R/H	—	—
1400 x 1050/60*4	1 400 x 1 050	65.2	60.0	122.6	R/H	—	—
1400 x 1050/75	1 400 x 1 050	82.2	75.0	155.9	R/H	—	—
1440 x 900/50*4	1 440 x 900	46.3	50.0	87.4	R/H	—	—
1440 x 900/60*4	1 440 x 900	55.9	60.0	106.5	R/H	—	—
1440 x 900/60	1 440 x 900	55.9	59.9	106.5	R/H	—	—
1600 x 900/50*4	1 600 x 900	46.3	50.0	97.0	R/H	—	—
1600 x 900/60*4	1 600 x 900	55.9	60.0	119.0	R/H	—	—
1600 x 1200/60	1 600 x 1 200	75.0	60.0	162.0	R/H	✓	✓
1680 x 1050/50	1 680 x 1 050	54.1	50.0	119.5	R/H	—	—
1680 x 1050/60	1 680 x 1 050	65.3	60.0	146.3	R/H	—	—
1680 x 1050/60*4	1 680 x 1 050	65.2	60.0	147.1	R/H	—	—
1920 x 1080/50	1 920 x 1 080	55.6	49.9	141.5	R/H	—	—
1920 x 1080/60*5	1 920 x 1 080	66.6	59.9	138.5	R/H	—	—
1920 x 1200/50	1 920 x 1 200	61.8	49.9	158.3	R/H	—	—
1920 x 1200/60*5	1 920 x 1 200	74.0	60.0	154.0	R/H	—	—

*1 Signal with ✓ in the plug and play column is a signal described in the EDID (extended display identification data) of the projector. The signal that does not have ✓ in the plug and play column can also be input if it is described in the format column. The resolution may not be selected in the computer even if the projector is compatible with the signal that does not have ✓ in the plug and play column.

*2 Pixel-Repetition signal (dot clock frequency 27.0 MHz) only

*3 It also supports signals with vertical scanning frequency of 1 / 1.001 times.

*4 When inputting appropriate analog signal, it can be displayed by making the setting suitable for the signal from the [PICTURE] menu → [RGB-SYSTEM]. For digital signal, the [RGB-SYSTEM] setting is unnecessary.

*5 VESA CVT-RB (Reduced Blanking)-compliant

Note

- A signal with a different resolution is converted to the number of display dots. PT-VMW60: 1 280 x 800
- The “i” at the end of the resolution indicates an interlaced signal.
- When interlaced signals are connected, flickering may occur on the projected image.
- The maximum transmission distance when connected with the long-reach communication method is 150 m (492'2"). In this case, the signal that the projector can receive is only up to 1080/60p (1 920 x 1 080 dots, dot clock frequency 148.5 MHz).
- Even the above signals exist, some image signals recorded in special method may not be displayed.

Notes on projector placement and operation

- Prevent hot and cool air from the air conditioning system to blow directly to the ventilation ports (intake and exhaust) of the projector.
- Do not stack projectors on top of each other.
- Do not block the ventilation ports (intake and exhaust) of the projector.

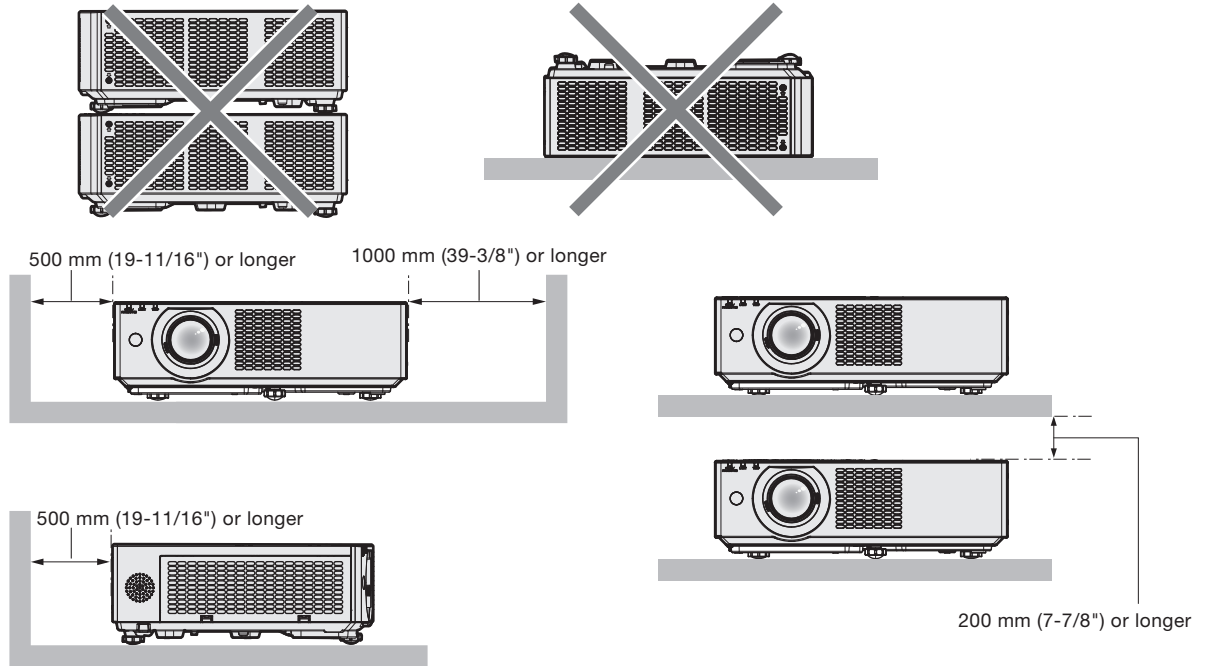

- Do not install the projector in a confined space. When installing the projector in a confined space, provide air conditioning or ventilation separately. Exhaust heat may accumulate when the ventilation is not enough, triggering the protection circuit of the projector.